



# **UNDERCARRIAGE HANDBOOK**

**Helping You get the Most from Your Undercarriage**



**0800 654 323** | **[www.west-trak.co.nz](http://www.west-trak.co.nz)**

## HELPFUL HINTS



# Tips for new undercarriage installations

**A NUMBER OF PRODUCT SELECTION, OPERATIONAL AND MAINTENANCE THINGS CAN BE DONE TO HELP PROLONG THE SERVICE LIFE OF YOUR UNDERCARRIAGE**

### TRACK ROLLERS & IDLERS

- Mixing new and old track rollers on the same side can overload the new ones as they sit lower than the worn ones, therefore taking a lot of extra weight
- If not replacing all new bottom rollers, it is recommended to fit all the better half on one side and all new ones on the other side. This keeps even pressure on each roller without overloading individual ones
- When replacing new rollers and idlers, do not travel long distances without stopping the machine frequently as they could overheat and seize. Stop every 4-5 minutes and go the opposite direction a little to help circulate the oil. This is standard precaution for the first 100 hours

### CHAINS BUNCHING UP

- This can be caused by wet working conditions or the machine sitting stationary for long periods, and moisture gets in causing seizure of the seals. To fix this, try pushing out the track pins, re-greasing and pushing back in. Driving along a riverbed to create some vibration may also help loosen it
- This can also be caused by putting bent grouser shoes onto new chains in a different order than they came off especially on wider shoes - 700, 800, 900mm

**CALL 0800 654 323 NOW TO DISCUSS YOUR NEEDS**

## HELPFUL HINTS



### FITTING DOZER CHAINS THE CORRECT WAY

- With Dozer chains, the grouser shoe lug goes closest to the front of the machine when looking at the top of the chains

### FITTING EXCAVATOR CHAINS THE CORRECT WAY

- The open end of the chain (not the master link) goes under the bottom rollers and over the sprocket end first

### GROUSER SHOES

- Always use the narrowest shoe possible for adequate flotation. The wider the shoes, the less life you will get out of the chains
- Always grind paint, scale or surface rust off shoes and chains when fitting. These must be metal to metal contact, otherwise the bolts will come loose and shoes may fall off
- Mud holes in shoes are to stop 'material packing' inside the chains under the plates. When the chain passes around the sprocket, the sprocket teeth will push the dirt out. Very necessary in coal, muddy, swampy, forestry and landfill conditions

### CHAINS JUMPING ON THE SPROCKETS

- If the chains are slipping or jumping on the sprockets, it can mean the sprockets are very worn. If the chains and sprockets are new, it may be the track adjuster spring is broken causing it to retract and loosening the chain tension
- Some sprockets are offset and will only fit one way; they could be on incorrectly and running into the side rails of the chains and not in the centre.
- Sprockets could be the wrong pitch for the chains or vice versa
- Worn track roller flanges can cause the chain to waver out to the side and become misaligned with the sprocket. Track guards will help to prevent this issue

## HELPFUL HINTS

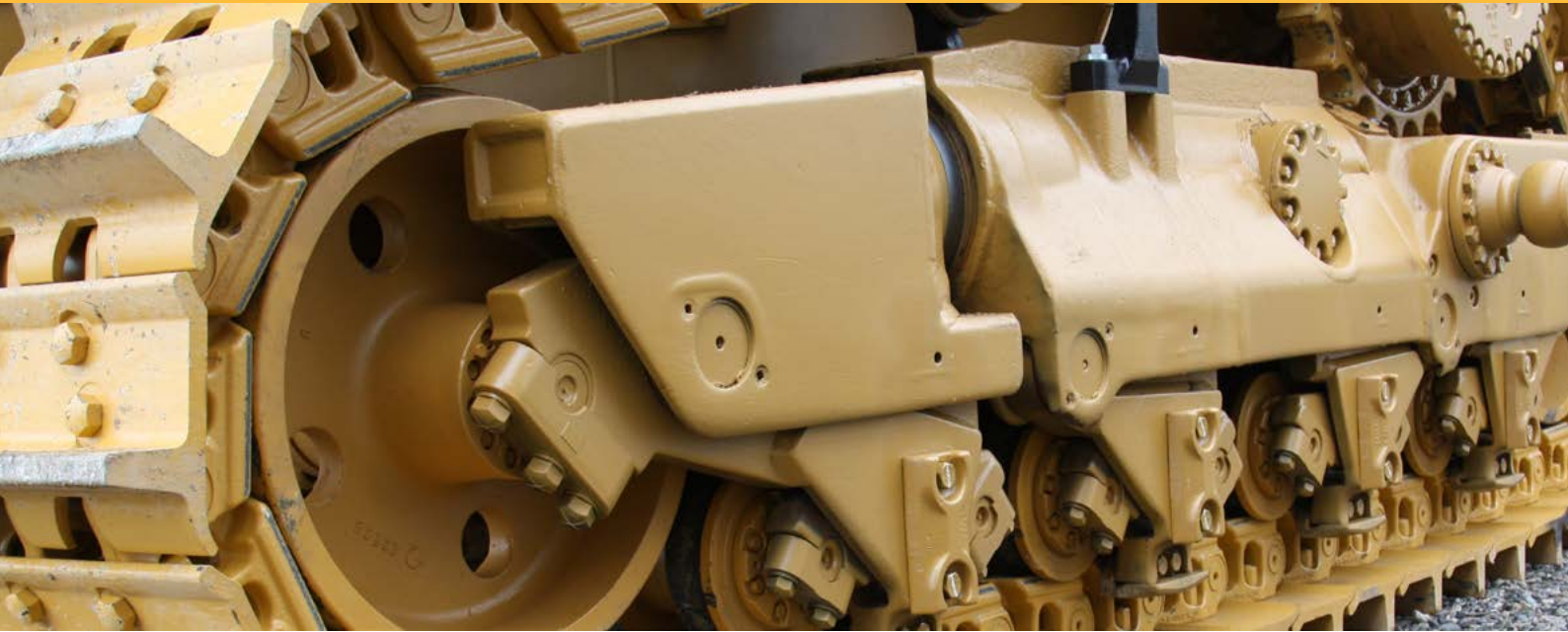

# Make your undercarriage last longer

### CHOOSING HEAVY DUTY, GREASE FILLED AND POLY SEALED EXCAVATOR CHAINS WILL:

- Extend external bush wear up to 20%
- Reduce internal bush wear up to 25% compared to dry chains
- Reduce undercarriage noise for operator comfort

### CHOOSING THE NARROWEST SHOE POSSIBLE, WITH GOOD FLOTATION WILL:

- Minimize internal wear on pins and bushes
- Reduce shoe wear and prevent bending or cracking
- Reduce stress and wear on the entire undercarriage system

### MINIMIZE REVERSING

- Excavator and Dozer chains are designed to operate with less wear when travelling forwards. Excessive reverse travel can cause faster undercarriage wear. The extra power required when reversing will also increase fuel consumption

### ALWAYS DIG OVER YOUR IDLERS

- It's important to note for excavator operation that digging over your sprockets will increase bush wear and possibly cause pin and bush cracking. Always dig over your idlers as the weight is on the chain links and not directly on the pins and bushes.

**CALL 0800 654 323 NOW TO DISCUSS YOUR NEEDS**

# HELPFUL HINTS



## CORRECT CARE AND MAINTENANCE WILL INCREASE SERVICE LIFE

- Ensure the correct track adjustment is maintained - check this regularly after installing a new set of undercarriage
- Measuring and monitoring of wear areas to determine any wear issues - especially in abrasive and high impact conditions
- Keep the undercarriage components as clean as possible at all times. If you allow the tracks to pack or build up with dirt, mud, dust and other ground products it will lead to increased wear rates, perceived lower power and increased fuel usage

## KNOW YOUR WORKING CONDITIONS

- Look at the conditions where your equipment is operating as this can be a major contributor to wear. High impact, abrasive or sandy materials on a wet site, will contribute to faster undercarriage wear
- In the past it was accepted in an abrasive environment that you would simply run SALT type dozer tracks to destruction, then replace the links. Now the preferred option is to carry out regular inspections and do a pin and bush turn (turning the pins and bushes 180 degrees) when they are worn to a certain level

## MAINTAIN GROUSER LUG HEIGHT

- Keeping a good lug height on your Grouser shoes will ensure proper traction and help reduce track slippage. A spinning track under load will increase the wear rate of your undercarriage system. Grouser relug bars can be used to build up your worn shoe lugs and maximise traction

## UNDERCARRIAGE PROJECTS



# 336D Excavator track change out

## UNDERCARRIAGE SUPPLY AND INSTALL SERVICE

We service what we sell and can now fit what we sell to your machine, with our new capabilities and a highly experienced team of undercarriage technicians

A full track component change-out was completed for two Cat 336, 40 tonne excavators with our Heavy Duty ITM Undercarriage

Talk to us today about getting your Excavator or Dozer in to West-Trak for a roll in, roll out undercarriage replacement



**CALL 0800 654 323 NOW TO DISCUSS YOUR NEEDS**

## UNDERCARRIAGE PROJECTS



# D10T Dozer track change out

Recently completed refurbishment for a D10T bulldozer, fitted with our genuine alternative 'ITM Mining' undercarriage

The work included removing the track frames, stripping the worn components off, and fitting new 'ITM brand' parts. The ripper frame pivot points were line bored and re-bushed also

With our specialist team of undercarriage technicians, you'll get a guaranteed, high quality product and service solution with full back up support

We provide our West Coast, Tasman, Marlborough and Canterbury customers with a complete undercarriage supply and installation service, including transport of machines from your site to our workshop and back



**DELIVERING THE SOLUTIONS YOU NEED TO STAY PRODUCTIVE**

# UNDERCARRIAGE HARDWARE

## HARDWARE

- A full range of Metric and Imperial Track bolts, Sprocket/Segment bolts, Roller bolts and hardened washers are stocked to suit all models of crawler equipment
- Track bolts, Segment bolts and Split Master bolts are 12.9 grade
- Roller bolts and Sprocket bolts are 10.9 grade
- All hardware is forged from alloy steels and heat treated to the specifications of OEM



TRACK BOLTS



SPROCKET /SEGMENT BOLTS



SPLIT MASTER LINK BOLTS



ROLLER BOLTS

## NOTES:

- Remove all paint and scale from points of connection
- Clean bolt holes from all grease and foreign materials
- Align parts together and thread bolts in by hand before applying torque setting
- Install self-interlocking track nuts with rounded corners against the link
- Tighten ALL bolts 70% of torque rating before applying the total torque value
- It is recommended to use OEM torque settings for all roller and sprocket bolts

CALL 0800 654 323 NOW TO DISCUSS YOUR NEEDS

# UNDERCARRIAGE HARDWARE

## Torque Settings for Track Bolts

### Method A - Conventional Method by Final Torque Setting

Metric Thread – Strength Class 12.9		
Bolt Size	Torque ft-lb	Torque Nm
M12 x 1	118 ± 5	160 ± 8
M14 x 1.5	184 ± 7	250 ± 10
M16 x 1.5	272 ± 14	370 ± 20
M18 x 1.5	427 ± 25	580 ± 30
M20 x 1.5	580 ± 30	786 ± 40
M22 x 1.5	760 ± 30	1030 ± 40
M24 x 1.5	936 ± 44	1270 ± 60
M27 x 1.5	1371 ± 66	1860 ± 90
M30 x 2	1917 ± 95	2600 ± 130
M33 x 2	2754 ± 120	3490 ± 170

UNF Thread – Strength Class 12.9		
Bolt size	Torque ft-lb	Torque Nm
1/2" - 20 UNF	132 ± 6	180 ± 9
9/16" - 18 UNF	191 ± 7	260 ± 10
5/8" - 18 UNF	265 ± 14	360 ± 20
3/4" - 16 UNF	472 ± 22	640 ± 30
7/8" - 14 UNF	752 ± 36	1020 ± 50
1" - 12 UNF	1121 ± 59	1520 ± 80
1 1/8" - 12 UNF	1630 ± 81	2210 ± 110
1 1/4" - 12 UNF	2197 ± 110	2980 ± 150
1 3/8" - 12 UNF	3053 ± 154	4140 ± 210

### Method B - Alternative Method by Pre-Torque Plus Additional Part Turn

Metric Thread – Strength Class 12.9			
Bolt Size	Pre Torque ft-lb	Pre Torque Nm	Final Torque Turn
M16 x 1.5	130	175	+ 1/3 turn
M18 x 1.5	280	380	+ 1/3 turn
M20 x 1.5	320	430	+ 1/3 turn
M22 x 1.5	370	500	+ 1/3 turn
M24 x 2	380	515	+ 1/3 turn
M27 x 2	400	540	+ 1/3 turn
M30 x 2	675	915	+ 1/3 turn

UNF Thread – Strength Class 12.9			
Bolt Size	Pre Torque ft-lb	Pre Torque Nm	Final Torque Turn
5/8"	130	175	+ 1/3 turn
3/4"	300	405	+ 1/3 turn
7/8"	480	650	+ 1/3 turn
1"	650	880	+ 1/3 turn
1.1/8"	650	880	+ 1/3 turn
1.3/8"	1100	1500	+ 1/3 turn

**NOTES:** These torque settings are a guide only. Some older machines may have a lower torque setting, please refer to your machine manual or contact us to confirm.

# UNDERCARRIAGE HARDWARE

## Track Chains with split master link Assembly Instructions

### WARNING

Install the new track chain according with safety precautions and procedures explained in your machine producer Operation and Maintenance Manual and/or Service and Repair Manual.

Failure to follow these recommendations and instructions could result in damages to your machine and track chain components

### IMPORTANT NOTES

- Thoroughly remove all protective coating from the master links
- Remove all grease or foreign matter from the bolt holes
- Remove all paint from mating surfaces of the links and shoes
- Ensure bolts are clean and apply anti-seize compound to the threads

Engage pin side links (A) and bushing side links (B) and check holes alignment. Screw in the four bolts (C) without fitting the shoes (the bolts must go easily in by hand). Do not force the track bolts into misaligned holes; damage to bolt and link threads will occur.

Remove the four bolts (C).

Position shoe (D) on the master link by aligning the bolt holes, then screw up all four bolts (C) fully by hand. Check that the split master link mating faces remains precisely aligned.

Use a suitable torque wrench (E) to tighten the four bolts (C). Tighten the bolts in order 1 to 4 as shown.

After installation, check the master shoe bolts (C) tightening torque after the first 100 machine working hours and again after 500 working hours.

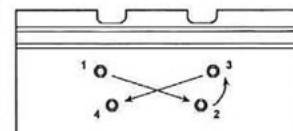
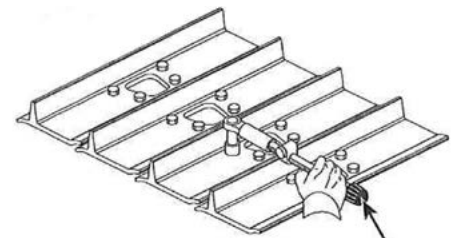
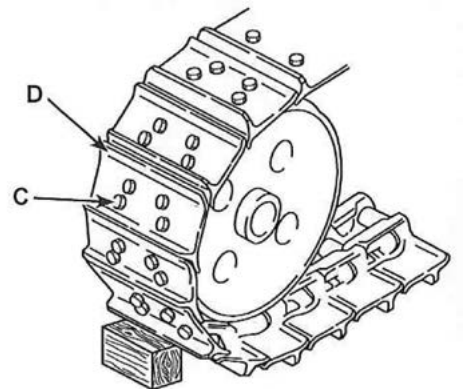
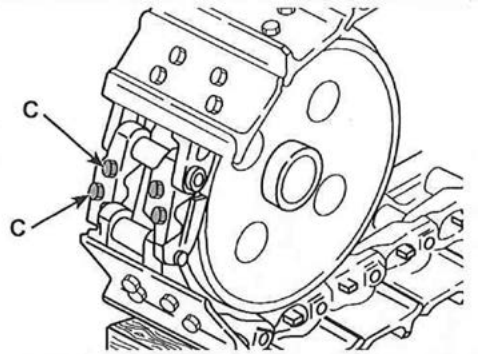
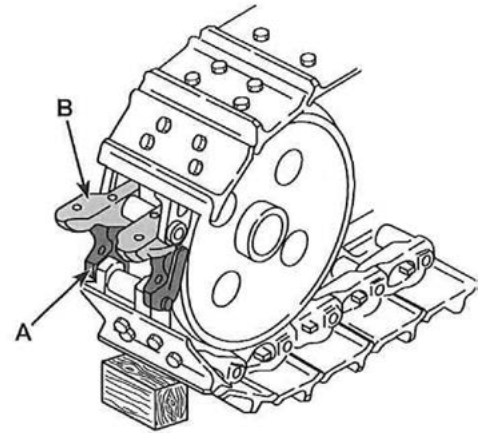

CALL 0800 654 323 NOW TO DISCUSS YOUR NEEDS

# UNDERCARRIAGE HARDWARE

## Split Master Link Torque Settings

### Method A - Conventional Method by Final Torque Setting

Metric Thread – Strength Class 12.9		
Bolt Size	Torque ft-lb	Torque Nm
M12 x 1	118 ± 5	160 ± 8
M14 x 1.25	184 ± 7	250 ± 10
M16 x 1.5	272 ± 14	370 ± 20
M19 x 1.5	480 ± 30	650 ± 30
M20 x 1.5	480 ± 30	650 ± 30
M22 x 1.5	553 ± 29	750 ± 40
M24 x 2	936 ± 44	1270 ± 60
M27 x 2	1371 ± 66	1860 ± 90
M30 x 2	1917 ± 95	2600 ± 130
M33 x 2	2574 ± 125	3490 ± 170

UNF Thread – Strength Class 12.9		
Bolt size	Torque ft-lb	Torque Nm
1/2" - 20 UNF	132 ± 6	180 ± 9
9/16" - 18 UNF	191 ± 7	260 ± 10
5/8" - 18 UNF	265 ± 14	360 ± 20
3/4" - 16 UNF	472 ± 22	640 ± 30
7/8" - 14 UNF	752 ± 36	1020 ± 50
1" - 12 UNF	1121 ± 59	1520 ± 80
1 1/8" - 12 UNF	1630 ± 81	2210 ± 110
1 1/4" - 12 UNF	2197 ± 110	2980 ± 150
1 3/8" - 12 UNF	3053 ± 154	4140 ± 210

### Method B - Alternative Method by Pre-Torque Plus Additional Part Turn

Metric Thread – Strength Class 12.9			
Bolt Size	Pre Torque ft-lb	Pre Torque Nm	Final Torque Turn
M16 x 1.5	130	175	+ 1/3 turn
M19 x 1.5	300	405	+ 1/3 turn
M20 x 1.5	320	430	+ 1/3 turn
M22 x 1.5	370	500	+ 1/3 turn
M24 x 2	380	515	+ 1/3 turn
M27 x 2	400	540	+ 1/3 turn
M30 x 2	675	915	+ 1/3 turn

UNF Thread – Strength Class 12.9			
Bolt Size	Pre Torque ft-lb	Pre Torque Nm	Final Torque Turn
5/8"	130	175	+ 1/2 turn
3/4"	300	405	+ 1/3 turn
7/8" (D7N, R, T)	250	340	+ 1/3 turn
7/8" (D8N, R, T)	480	650	+ 1/3 turn
1"	650	880	+ 1/3 turn
1.1/8"	650	880	+ 1/3 turn
1.3/8"	1100	1500	+ 1/2 turn

**NOTES:** These torque settings are a guide only. Some older machines may have a lower torque setting, please refer to your machine manual or contact us to confirm.

## Grouser Shoes

- The most important wear is the relative height of the grouser lug from the top of the shoe. A depth gauge is used to measure this



### ACCELERATED WEAR OF OVERLAPPING SURFACES

- This is normally caused by a worn snaking chain and is eliminated by tightening or replacing the chains



### SEVERE WEAR OF THE END OF THE GROUSER

- This is especially noticeable on single bar grousers and is usually caused by using shoes too wide for the type of ground the tractor is operating on. The use of a narrower shoe will eliminate this problem



### BENDING AND CRACKING

- This is due to excessive impact or stress on the shoes. The use of narrow shoes or Extreme Service (ESS) shoes will assist



### ENLARGED BOLT HOLES

- This is caused by movement between the chain and shoe due to loose bolts or machine motion
- Reduced shoe size or the use of shoes with less penetration (i.e. double or triple grousers) and accurate control of the bolt torque will help prevent this happening



# TROUBLE SHOOTING & SOLUTIONS

## Track Links

- The normal wear area on track links is on the surface that contacts the rollers and idlers



### EXCESSIVE SIDE RAIL WEAR

- Besides the operational conditions, steep ground or frequent sudden turns, this wear could be caused by track misalignment, excessive chain snakiness or worn chains



### INDENTATIONS ON INTERNAL SURFACE OF RAIL

- This is caused by the sprocket teeth rubbing on the inside of the link because of sloping ground, misaligned sprocket and chain or a severely bent chain. Adjust chain tension and check alignment



### PIN BOSS SIDE WEAR

- Caused by contact with the outside flange of the rollers. Should it occur before 100 percent of the link wear then the rollers are beyond their useful life and should be replaced



### EXCESSIVE FACE WEAR

- This wear is caused by snaking of the links or highly abrasive working conditions
- The use of track guards or fitting of lubricated chains can reduce this wear



## Track Links

### PIN BOSS WEAR BY TRACK GUARDS

- This results from excessive snakiness of the chain due to sprocket and roller misalignment, uneven roller wear or working on steep slopes
- Check sprocket alignment and rotate some rollers will help



### RAIL CORNERS GOUGED

- Caused by severe shock loads usually transmitted by the rollers to links
- Besides operating conditions (heavy work, speed, weight and power of machine) the situation can be aggravated by the size of the shoes and/or track tension.
- A remedy could be to reduce the shoe size and/or adjust the chain tension



### CRACKS OR BREAKAGES OF THE MOST STRESSED AREAS

- Most breakages are caused by torsional stress transmitted to the link structure when the machine is used in a severe impact application
- To reduce this failure, narrower shoes can be used and the chain tension regularly adjusted



### BUSHING COUNTERBORE AND PIN BOSS DEFORMATION

- If this is not caused by incorrect tooling being used when assembling or disassembling the chain, then it is caused by bending stresses in the pins and bushes
- This problem can be reduced by fitting smaller shoes and by having the correct chain tension

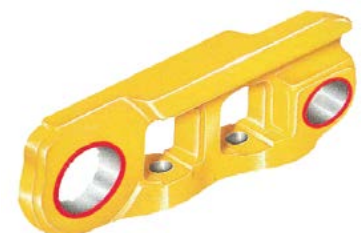

## Pins & Bushes grease filled type

- The internal pin and bush wear on greased and sealed chains is measured by the chain stretch. This is done by measuring the pin centres over 4-5 links and comparing to new chain specs.

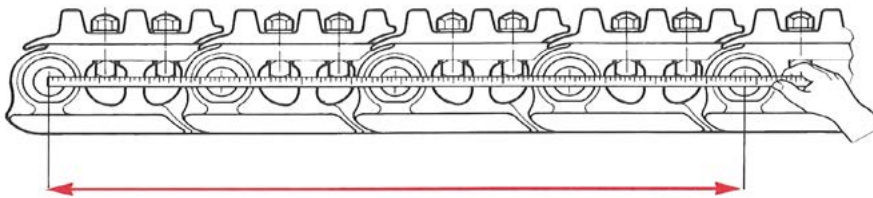

### WORN PIN END

- Besides the obvious factor of hillside operation and uneven ground, this type of wear is caused by incorrect chain tension and roller wear
- If chain elongation has not reached the limit, then adjust chain tension and rotate some rollers
- If this pattern of wear starts immediately after installing a new undercarriage, then check position of the track guards is not too close to the chain



### LOOSE PINS

- If there is no obvious fault such as incorrect assembly or disassembly, then this can be caused by bending stresses during heavy operation of the machine
- To eliminate this, replace any worn shoes, check bolt tension and/or fit narrower shoes



## Pins & Bushes grease filled type

### EXTERNAL BUSHINGS

- Wear is caused at the point of contact between the bushing and the sprocket tooth. To measure this wear, use a small outside calliper



### CRACKING OR BREAKING OF SURFACES IN CONTACT WITH SPROCKET

- Due to excessive wear either externally or internally, will allow the bush to break
- It could also be caused by to heavy working conditions or packing sprockets. To reduce this effect, check and adjust chain tension and to eliminate it completely, keep wear limits below 100 percent



### PIN BREAKAGES

- Main cause of this failure is extreme shock or high static loads which occur when the machine works on rocky ground and/or when material packs in the sprocket causing extreme tension on the track chain
- Protect the track chain and sprocket from material packing under the shoes by using shoes with mud holes in



## Pins & Bushes oil filled S.A.L.T type

- The normal bush wear is on the external surface. The bushing wears evenly and should be measured in the centre of the wear area
- One way to measure external wear is to evaluate the distance from the underside of the shoe (top of link) to the centre of the wear area on the bushing
- A depth gauge or ultrasonic wear indicator tool can be used.

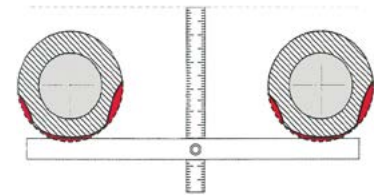
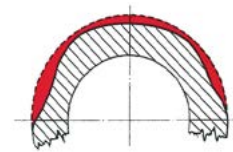

### PIN GALLING

- This is due to interference between the pin and bushing in the press fit contact areas and is caused by fine abrasions getting in or the pins bending under load
- This effect is of no consequence for greased chains and the pin can be reused. However for oil filled S.A.L.T chains this may damage the seals causing oil to leak. The pins should not be reused.



### PIN SPALLING

- All spalling is due to large bending stresses in heavy working conditions
- Besides the application of the machine, this can be caused by excessive chain tension due to build up and packing of material
- Adjust the chain correctly and protect against packing of rocky material between chain and sprocket



## Lower Track Rollers

- The tread wear of the roller is most important and is measured on the roller diameter. The most suitable tool is a large outside calliper.
- The correct measurement is to take the least diameter of either tread on the roller which will be the one with the highest wear. Because of the difficulty in measuring the rollers on the machine, it is usually sufficient to measure the front (nearest idler) and back (nearest sprocket) roller as the greatest wear occurs at these two points due to the rocking action of the machine

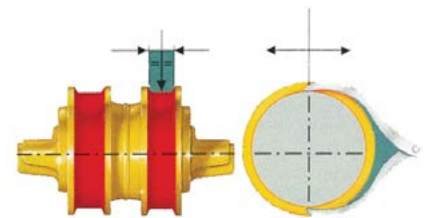

### EXCESSIVE SIDE FLANGE WEAR

- Besides operational conditions, this wear can be caused by misalignment or excessive slackness of the chain
- If the rollers have not reached their wear limit, then adjust the chain tension and rotate some of the rollers
- It should be noted that double flange rollers have a longer life and the correct sequence of double and single flange rollers is important
- If longer life is required due to the operating conditions, then more double flange rollers can be fitted

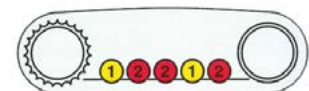
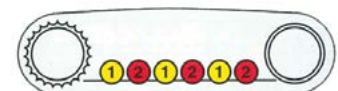
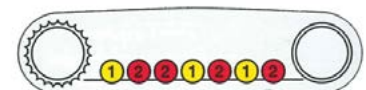

### TOP FLANGE DEFORMATION

- This is caused by contact of the link pin boss or due to the chain sliding over the flanges because of exceptional snaking of the chain. If the chain is not completely worn out, adjust the chain tension, realign the rollers and reposition track guide rails



## Top Carrier Rollers

- The normal wear condition can be measured as for the bottom rollers. Other wear patterns are analysed below



### EXCESSIVE FLANGE SIDEWEAR

- This can be caused by hillside operation, using special offset grousers, and incorrect alignment or track tension
- To increase the roller life, align carrier rollers with idler and sprocket and rotate top rollers if more than one are fitted to the machine



### FLAT SPOTS AND IRREGULAR WEAR

- This is usually caused by material packing under the top carrier roller and restricting its rotation
- Rollers should be cleaned and all material removed regularly



## Idlers

- Radial tread wear is the most important factor. The easiest method of measuring tread wear is to measure the depth of the tread from the centre of the idler.
- It must be noted that the centre rim has not been changed from the original diameter by abnormal wear or obvious after inspection



---

### EXCESSIVE FLANGE SIDEWEAR

- The main causes of this wear is abrasive soil conditions, hillside operation or excessive turning
- Other factors influencing side wear can be incorrect roller alignment or chain tension
- To reduce side wear to a minimum, make sure the correct chain tension is used and the idler is correctly aligned in the track frame



---

### TOP FLANGE WEAR

- Usually caused by material packing under the rail or excessive idler tread wear. To eliminate this, make sure that the chain is correctly adjusted



## Idlers

### TREAD CRACKING AND SPALDING

- This can be caused by high impact loads due to heavy working conditions or by excessive wear of the idler
- The condition of the chain can also contribute to the effect
- Unfortunately the factors which lead to the breakdown of the idler can not be controlled and therefore the only remedy will be not to exceed the wear limits of the idler or any of the undercarriage components



## Sprockets & Segments

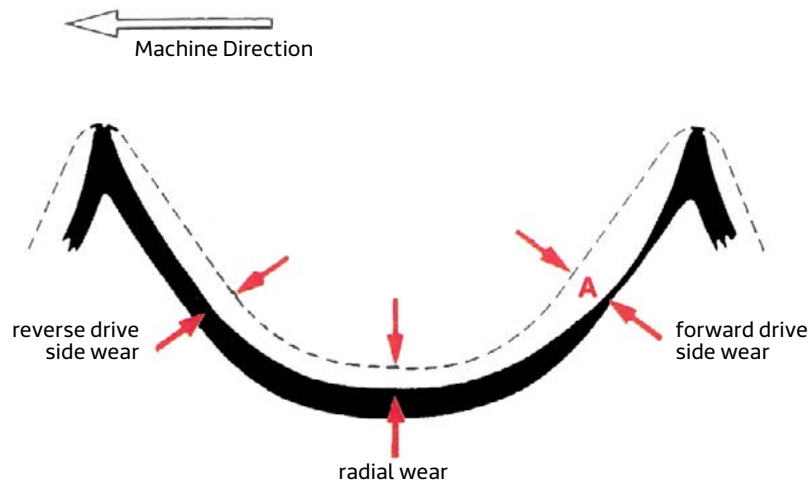

- Sprocket wear measurement is one of the most difficult to take. Under normal conditions of work, the wear occurs in such a way that no trace of the original toothing remains as a valid reference to base measuring the wear on
- Consequently it is not possible to get the exact data and for any evaluation, it is always necessary to refer to an unused sprocket of the same type
- As a general rule, the sprocket has to be replaced or rimmed when the wear line reaches the limits as outlined in the figure above
- Due to the fact that the wear is never even, the point where there is major wear must be considered

# UNDERCARRIAGE MANAGEMENT



## Active wear monitoring, reduced running costs

**WE CAN MONITOR YOUR UNDERCARRIAGE WEAR PERFORMANCE TO HELP PLAN FOR UPCOMING REPLACEMENTS AND PREVENT UNEXPECTED BREAKDOWNS**

Lack of undercarriage management can account for more than half of a machine's maintenance costs. That's why we offer a comprehensive program to measure and monitor your undercarriage system.

The ITM Track Advice Measurement System uses the most advanced diagnostic equipment available, like the Ultrasonic Wear Indicator and mobile App.

With this technology we can accurately monitor your undercarriage wear rates and remaining service life so you can plan maintenance, and schedule downtime easily.

The wear analysis can be completed on site, providing real-time data that will help you make informed decisions.

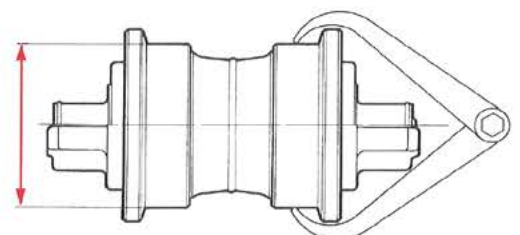
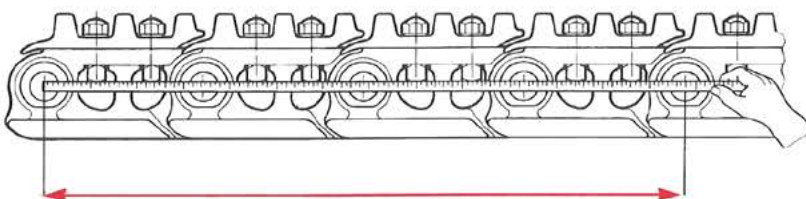

**CALL 0800 654 323 NOW TO DISCUSS YOUR NEEDS**

# UNDERCARRIAGE MEASURE UP FORM

**Help us to help you. Fill out this form with your undercarriage measurements and send to us for a report on the remaining service life of your parts.**

Company Name: .....

Phone: (    ) .....

Email: .....

Serial No: .....

Contact person: .....

Mobile: .....

Machine Model: .....

Hours at time of inspection: .....

Please record all measurements below in millimetres (mm). Please note for Excavators - the sprockets should be facing the back of machine to accurately define the R/H and L/H sides.

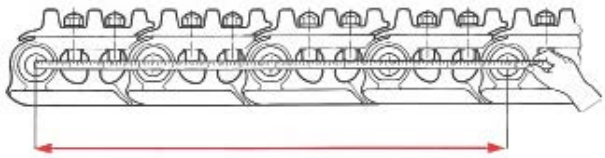
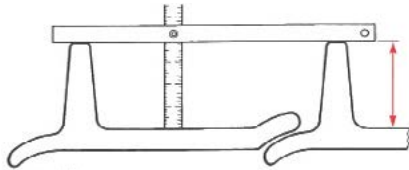
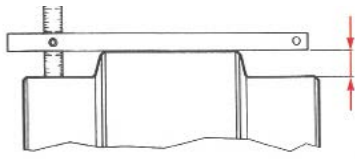
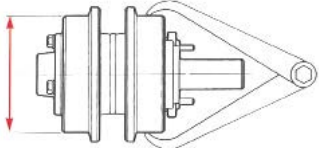
<p>Chain stretch (Measure 4 sections of links)</p> <p>R/H: ..... L/H: .....</p> <p>Brand: ..... Part No: .....</p>	
<p>Shoe Width: .....</p> <p>Number of Shoes: .....</p> <p>Rail Height R/H: ..... L/H: .....</p>	 <p>Shoe Lug Height (A)R/H: ..... L/H: .....</p> <p>Shoe Thickness (B)R/H: ..... L/H: .....</p>
<p>Idler Diameter (B): .....</p> <p>Front Idler Flange (A)R/H: ..... L/H: .....</p> <p>Rear Idler Flange (B)R/H: ..... L/H: .....</p> <p>(High Track Dozers)</p>	  <p>Top Roller Diameter R/H: 1) ..... 2) ..... 3) .....</p> <p>Top Roller Diameter L/H: 1) ..... 2) ..... 3) .....</p> <p>(Measure from sprocket end)</p>
<p>List Roller Brand(s) (if possible) .....</p>	<p>Track Roller diameter R/H (Measure from sprocket end)</p> <p>1) ..... 2) ..... 3) ..... 4) ..... 5) .....</p> <p>6) ..... 7) ..... 8) ..... 9) ..... 10) .....</p> <p>Track Roller diameter L/H (Measure from sprocket end)</p> <p>1) ..... 2) ..... 3) ..... 4) ..... 5) .....</p> <p>6) ..... 7) ..... 8) ..... 9) ..... 10) .....</p>
<p>Outside Bushing Diameter: .....</p> <p>R/H: ..... L/H: .....</p>	<p>Width of Sprocket Tip: .....</p> <p>R/H: ..... L/H: .....</p> <p>Number of Holes: .....</p> <p>Number of Teeth: .....</p>



***Delivering the solutions you need to stay productive***

**CALL US TODAY FOR EXPERT ADVICE ON GETTING THE MOST FROM YOUR UNDERCARRIAGE SYSTEM**

Machine names and part numbers are for reference only.  
All parts are high-quality replacement parts and are not produced by the original equipment manufacturers.

**Contact us:**



**Phone us on**  
0800 654 323



**Fax us on**  
03 789 8093



**Email us on**  
[sales@west-trak.co.nz](mailto:sales@west-trak.co.nz)



**Visit our Website**  
[west-trak.co.nz](http://west-trak.co.nz)



**Our Address is**  
PO Box 164, Westport 7866

**AUCKLAND • TAURANGA • WESTPORT • CHRISTCHURCH**